

1,092,417.

Patented Apr. 7, 1914.

2 SHEETS-SHEET 1.

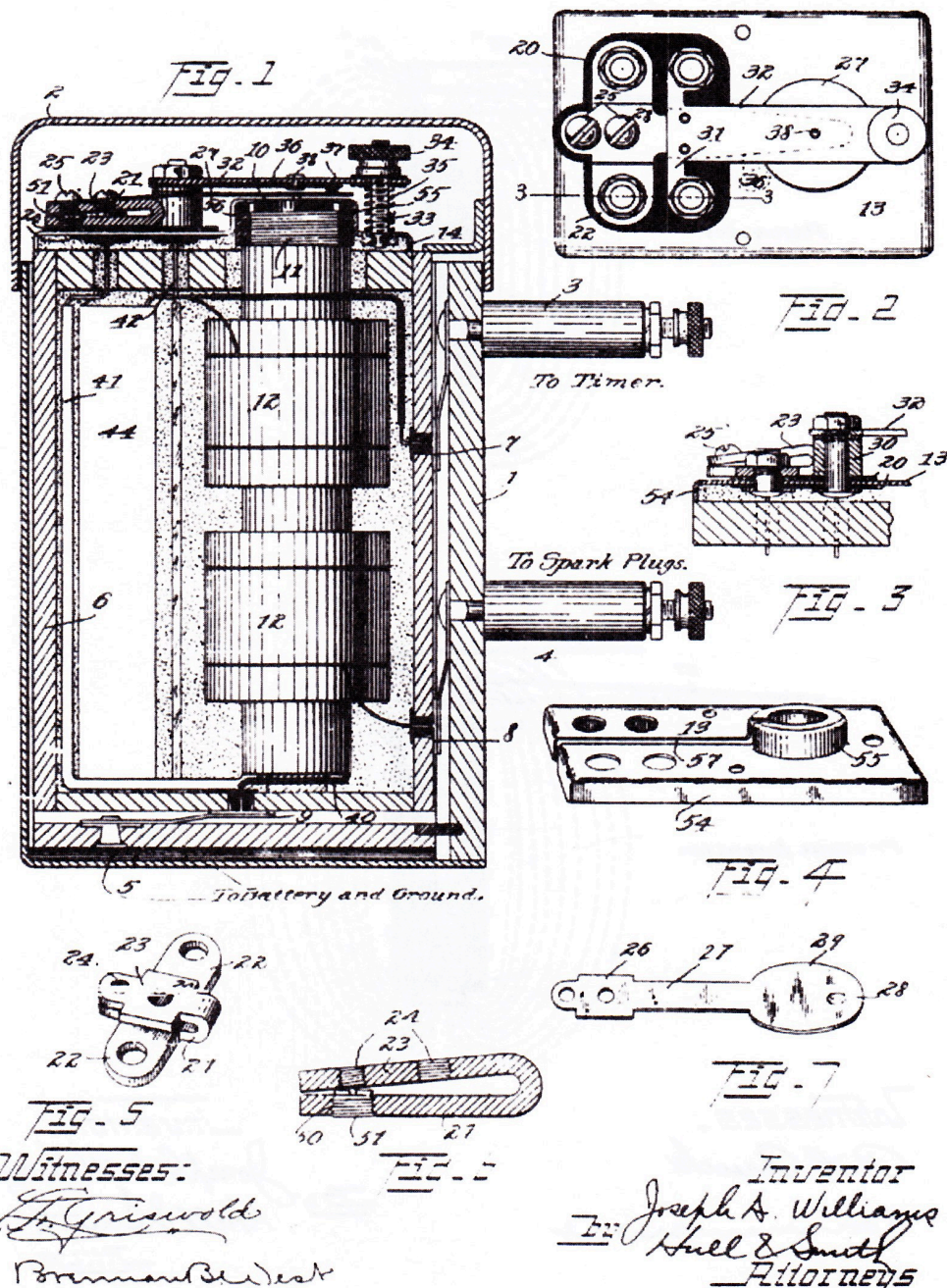

Photo 6: Illustration from Joseph A. Williams 1914 patent for the K-W coil showing the various parts of the coil. Although Williams attached little significance to the cushion spring on the upper contact bridge, some Ford engineers thought that it was this feature that made the K-W coil superior to the other coils then on the market.